



LUNES DE PATENTES – Madrid, 29 de Noviembre de 2010



# Out of the claims – but (still) inside the risk

How infringement under doctrine of equivalence and indirect infringement open the door to serious business risks



INTRODUCTION

## Patent Attorneys – The Men in Black

Does your client love you?

**We are fighting against ugly aliens,  
we are using complicated weapons,  
we are talking in a strange language, and  
and look strange ourselves**





INTRODUCTION

# Patent Attorneys – The Men in Black

Fight against ugly Aliens ... somebody must do the job



□ □ □ □ □ □ □ □  
□ □ □ □

□ □ □ □ □ □ □ □ □ □  
□ □ □ □  
□ □ □ □ □ □ □ □ □ □  
□ □ □ □





INTRODUCTION

# Patent Attorneys – The Men in Black

Logical development ... let's get serious !

© Original Artist

Reproduction rights obtainable from  
[www.CartoonStock.com](http://www.CartoonStock.com)



search ID: cwlh822

"After fire and the wheel, it was only logical to invent the patent attorney."

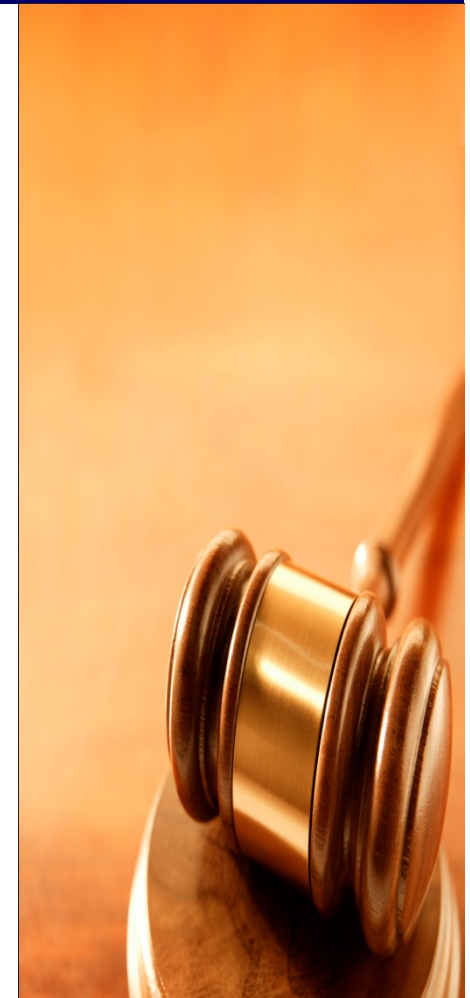



# Doctrine of Equivalence

The Protocol to Art. 69 EPC

Germany – 100 years of Doctrine of Equivalence

Out of the claims and not equivalent:

*Non-inventive improvements – Missing features – Solution to a different problem – Deteriorated embodiments*

On the knives edge – Landmark decisions from 2002

Great Britain – Different view of the same topic?



## Always trouble with equivalents ...

### The birth of the Doctrine of Equivalents in the U.S. ...

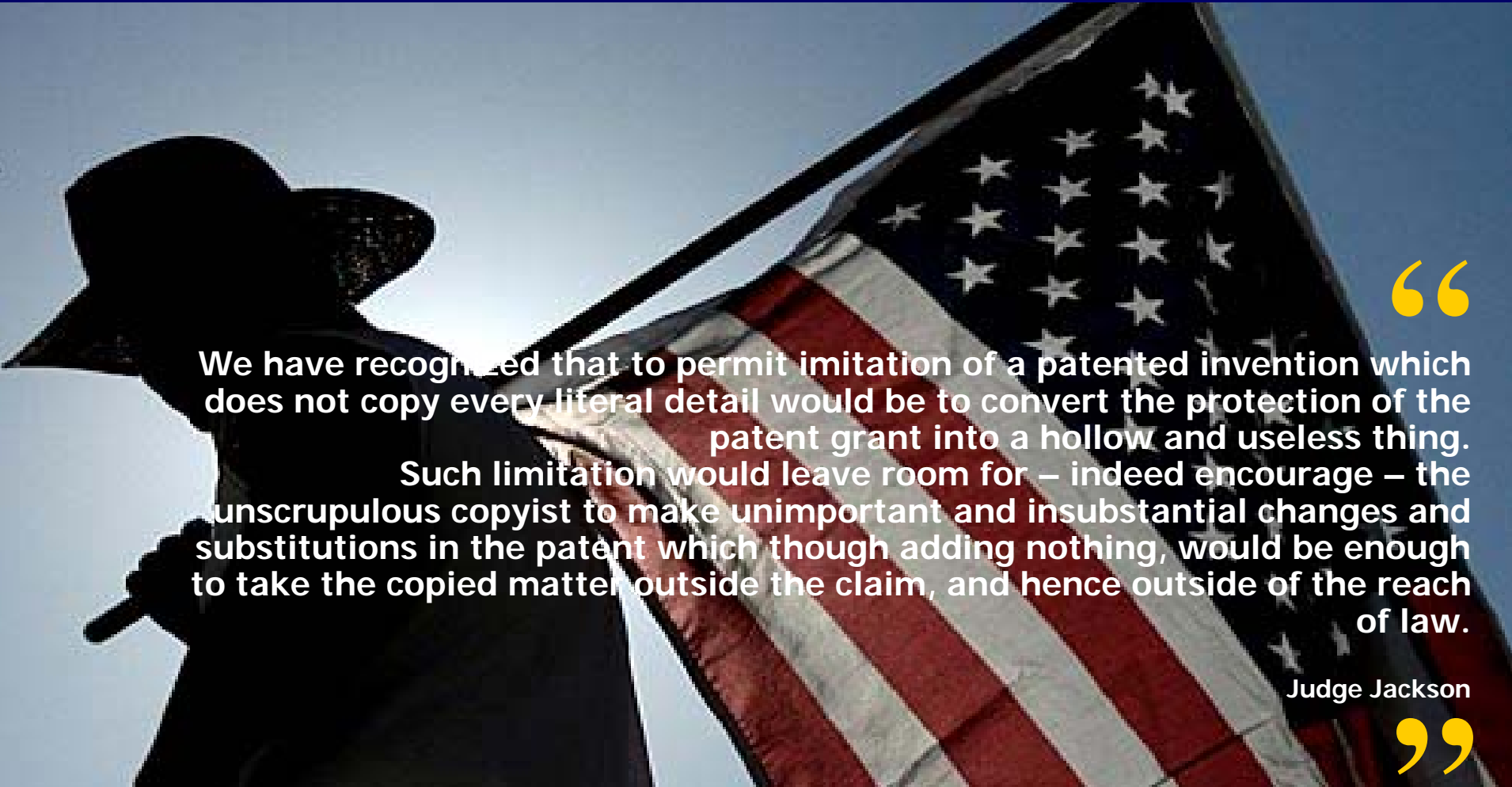

We have recognized that to permit imitation of a patented invention which does not copy every literal detail would be to convert the protection of the patent grant into a hollow and useless thing. Such limitation would leave room for – indeed encourage – the unscrupulous copyist to make unimportant and insubstantial changes and substitutions in the patent which though adding nothing, would be enough to take the copied matter outside the claim, and hence outside of the reach of law.

Judge Jackson





# The birth of the of the Doctrine of Equivalence

## ... and its dilemma

The Doctrine of Equivalence essentially holds that something different from that what a patent claims can infringe, so long as the differences between the claimed and unclaimed subject matter are minor. It sounds so simple. But in practice, it has proven to be the most difficult and least predictable of all doctrines in patent law to apply. Even judges cannot agree on its contours. Imagine the dilemma for lawyers! Pity law jurors!

Chief Judge Michael, CAFC







# The shave of things to come

Epilady (rotating blades) versus Lady Remington (rubber ball with slots)

## Silk·épil® Xpressive

The gentle way to discover  
beautifully smooth legs

**NEW**  
Wet&Dry







# The shave of things to come

Same subject matter – quite different decisions

Infringement						
Preliminary injunction	1				NO	YES
	2				YES	NO
Main case	1	YES	NO	YES	NO	YES
	2					YES



# Art. 69 EPC

Theoretically, equivalence is ruled by European law, but ...



**2010**

**38 members + 2 extension countries having signed the EPC, including the protocol, covering a market of 570 Mio inhabitants**







## Art. 69 EPC - claims are open for interpretation

Looking for a compromise between protection for the patentee and legal certainty for the public

“

The extend of the protection conferred by a European patent or European patent application shall be determined by the claims. Nevertheless, the description and drawings shall be used to interpret the claims.

”





# The Protocol to Art. 69 EPC

## The British view

“

**(1) Art. 69 should not be interpreted as meaning that the extend of protection conferred by a European patent is to be understood as that defined by the strict literal meaning of the wording used in the claims, the description and drawings being employed only for the purpose of resolving an ambiguity found in the claims.**

”



# The Protocol to Art. 69 EPC

The German view

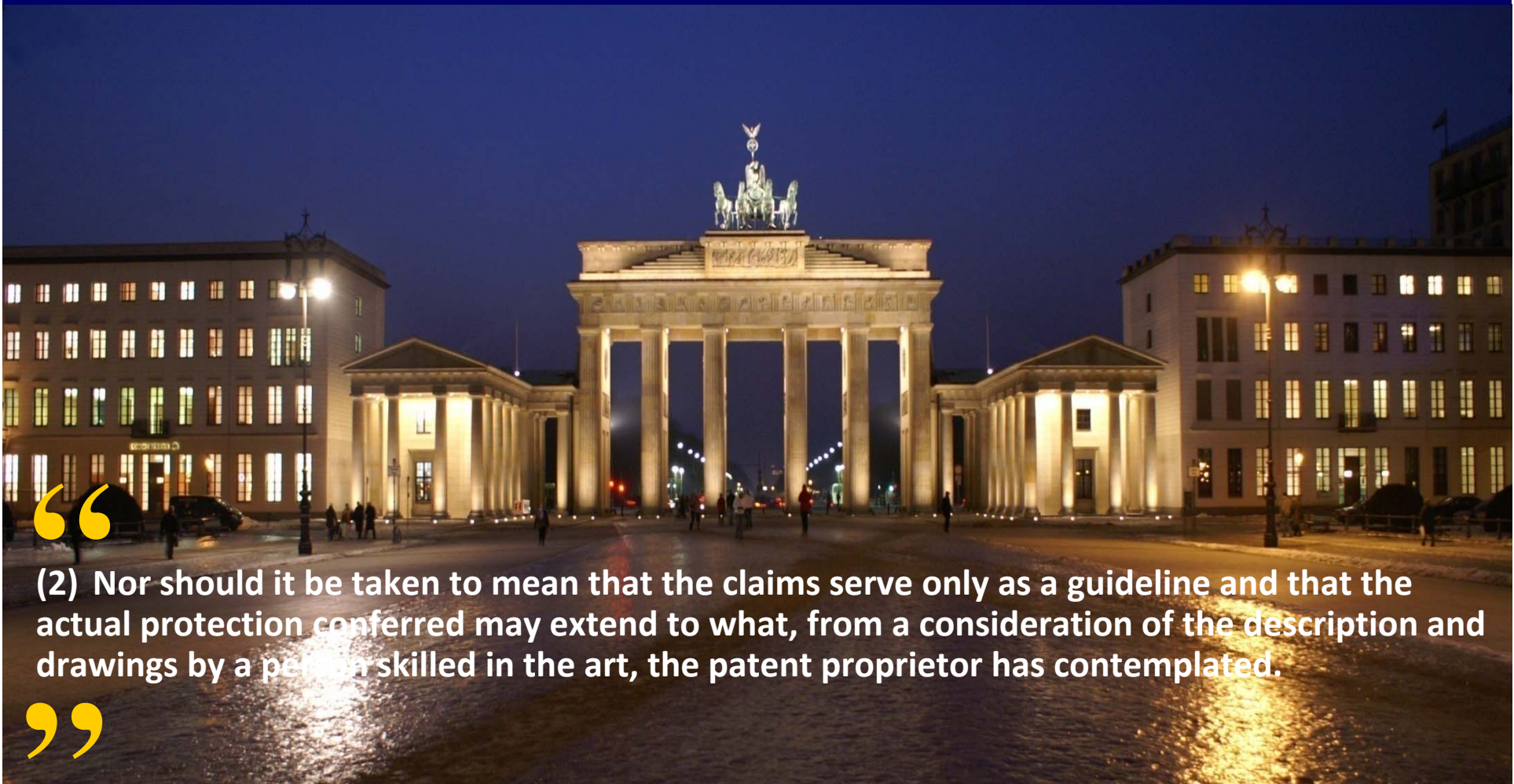

“

(2) Nor should it be taken to mean that the claims serve only as a guideline and that the actual protection conferred may extend to what, from a consideration of the description and drawings by a person skilled in the art, the patent proprietor has contemplated.

”





# The Protocol to Art. 69 EPC

The result from the Munich EPC Revision Conference (2000)

“

On the contrary, it is to be interpreted as defining a position between these extremes which combines a fair protection for the patent proprietor with a reasonable degree of legal certainty for third parties... For the purpose of determining the extent of protection conferred by a European patent, due account shall be taken of any element which is equivalent to an element specified in the claims.

”





## Rulings of the German Supreme Court

Change of paradigm from 1908 to 1910

“

**1908**

The interpretation of a patent must not deprive the claims from ist definition of the invention and the scope of protection.

”

“

**1910**

Claims do not serve the purpose to define the scope of protection in each and every detail, since any evaluation whether a feature is important or not would delay the examination in an inadmissible manner.

”



## Strange ways of German patent law

Consider this example

**Claim 1:**

**A hair care composition comprising 25 to 75 % b.w. of an anionic surfactant, preferably sodium dodecyl sulphonate, and 75 to 25 % honey.**

**Are these alternatives encompassed by the claim?**

1.50 % sodium dodecyl sulphonate + 50 % honey

2.50 % sodium dodecyl sulphonate + 50 % maple juice

3.10 % sodium dodecyl sulphonate + 90 % honey

4.50 % sodium dodecyl sulphonate + 50 % sweetener, preferably glucose



# Doctrine of Lindenmeier

Serious mismatch between protection for the patentee and legal certainty for the public

## Legal basis

### Each patent encompasses three scope of protections (1930)

**Example:** Hair care composition comprising 25 to 75 % of an anionic surfactant, pre-ferably sodium dodecyl sulphonate, and 75 to 25 % of of honey.



1. The first level of scope of protection refers to the literal object of the invention, that is the literal wording of the claims. **Example:** A composition comprising 50 % of sodium dodecylbenzene sulphonate (= anionic surfactant) and 50 % honey would be literally encompassed from the claims.
2. The second level encompasses the first level + all equivalents + also deteriorated embodiments. **Example:** A composition comprising 50 % sodium dodecylbenzene benzene and 50 % maple juice would be also within the scope of protection, since maple juice could be regarded as an equivalent for honey. Also a composition comprising only 10 % of the surfactant and 90 % of honey would be covered, even in case the results would be so bad that the problem underlying the invention is not solved.
3. Finally, the third level covers also the general thought of the invention. **Example:** Even a composition comprising 50 % sodium dodecyl sulphonate and 50 % glucose would be covered, since one may interpret the technical teaching so broad that instead of honey every sweetener could be added.

With the implementation of Art.69 EPC and the Interpretation Protocol into national law the so-called „Threefold Theory“ of Lindenmeier (which in deed has been a Twofold Theory) found its end in 1976.





# How to define an equivalent ?

German Supreme Court distinguishes between two groups

## Decision “Ski boot seal” (Skistiefelverschluss) from 1969

For the questions whether two embodiments are equivalent is mandatory, that at the priority day one skilled in the art was able to identify the variation as an equal solution to the problem

**Full equivalents**  
 (“glatte Äquivalente”)

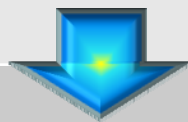

Obvious with respect to technology, underlying the examination by the patent office

**Equivalents in part**  
 (“nicht-glatte Äquivalente”)

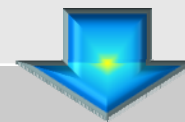

For identification an inventive step is necessary, therefore not underlying examination by the patent office



BGH X-ZR 54-66 (1969)

Bundesgerichtshof





# Non-inventive improvements

## Lack of inventive step proofs non-equivalence

### Legal basis

#### Formstein (Moulded brick) (1986)

Object of the patent has been a moulded brick containing specific drains for dewatering of rain water. The alleged infringer used conventional bricks which were placed with spaces between them and a minor slope to achieve the same effect.

#### Decision of the Bundesgerichtshof

1. The scope of protection a patent provides does regularly encompass equivalents of the embodiments protected by the patent. However, the argument that in view of the prior art the equivalent embodiment does not represent a patentable invention, is admissible.

2. Obviously, placing conventional bricks with spaces between them and a slope in order to facilitate dewatering, represents a non-inventive development of the well known prior art. However, a patent can only provide protection for embodiments which are patentable. Therefore, any embodiment lacking an inventive step cannot be covered by the patent and consequently does not represent an equivalent to the patented invention.



BGH X-ZR 28-85 (1986)  
Bundesgerichtshof

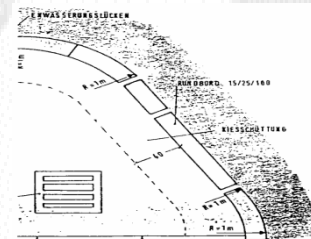



## Non-inventive improvements

The “moulded brick” argument in the context of other legislations

“

**It is wrong to prevent a man from doing something which is merely an obvious extension of what has been doing or what was known in the art before the prior date of the patent granted.**

**Gillette vs. Anglo American Trading Co. (U/K, House of Lords, 1913)**

”







## Non-inventive improvements

The “moulded brick” argument in the context of other legislations (2)

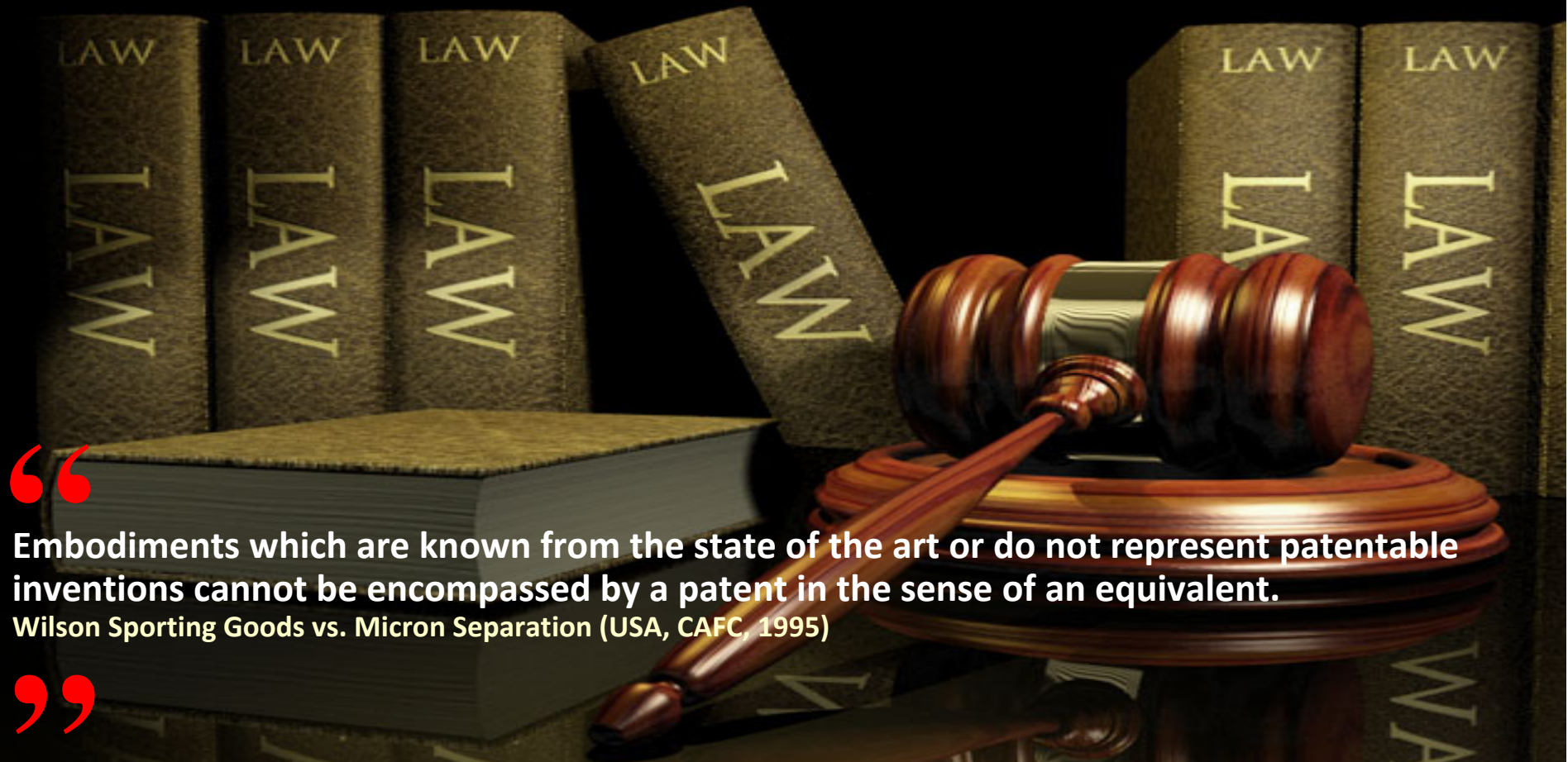

“

**Embodiments which are known from the state of the art or do not represent patentable inventions cannot be encompassed by a patent in the sense of an equivalent.**

**Wilson Sporting Goods vs. Micron Separation (USA, CAFC, 1995)**

”



## 1.3. Out of the claims and not equivalent

# Non-inventive improvements

## Limits of the “moulded brick” argument

### Legal basis

#### Kontaktfederblock (Contact spring block) (1999)

Object of the patent has been a contact spring block for electrical relays, comprising said contact springs in parallel rows of blocks. The infringing product was not only similar, but identical. The defendant argued that the patent was not enforceable due to lack of patentability.

#### Decision of the Bundesgerichtshof

1. The „Formstein argument“ requires that the infringing alternative makes use of every feature of the claim of the respective patent. In case, however, the infringing embodiment represents nothing more than a identical copy of what has been protected in the patent, the argument the patent does not represent a patentable invention is void.

**According to German law (different for example to Great Britain) the invalidity argument cannot be used in an infringement case, but must be presented in a parallel invalidity complaint.**

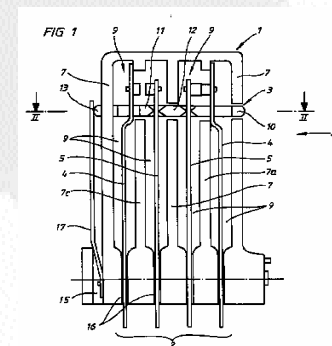

BGH X-ZR X-ZR 22-97

Bundesgerichtshof



# Non-equivalent alternatives

## Supreme Court defines two key questions

### Legal basis

#### Ionenanalyse (Ion analysis) (1988)

Object of the patent has been an equipment for analysis of heavy metal ions using membranes for the separation which were arranged in a defined manner. The alternative embodiment used the same technology and the same membranes, but had chosen a different form of arrangement.

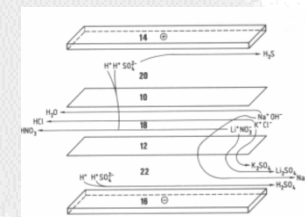

#### Decision of the Bundesgerichtshof

1. The scope of protection a patent provides encompasses also alternative embodiments, which at the day of priority one skilled in the art was able to discover and to identify as an equivalent solution to the problem.

This is considered to be a Landmark decision in German case law on equivalence, since for the first time the key questions „does it work in the same way“ and „has been identifiable at the day of priority“ were raised by the Supreme Court.



BGH X-ZR X 5-87 (1988)

Bundesgerichtshof





## Non-equivalent alternatives

Missing features proof that it does not work in the same way

### Legal basis

#### Batteriekastenschnur (Accumulator box cord) (1989)

The patent covered a cord for transportation of heavy battery backs which was saved against unwanted opening by specific lockings attached to the end of the cord and forming a carrier handle. The alternative embodiment encompassed all elements of the claim with the exception of two features which – according to the specification – were important to achieve a improved stability of the equipment.

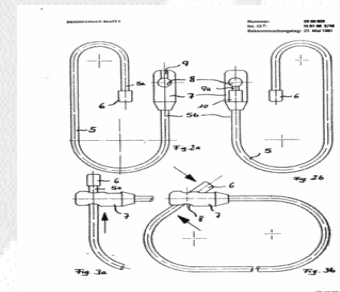

#### Decision of the Bundesgerichtshof

1. The scope of protection a claim provides has to be in balance with the need for legal certainty for the public, in order to make sure, that the scope of protection is foreseeable for every third party.
2. The public needs to trust that the invention protected by the patent is fully described by the features of the claim.
3. In case an alternative embodiment explicitly renounces to make use of at least one feature of the claim, there is no need for the public to estimate that the alternative works in the same way. Consequently, such alternative cannot be covered by the Doctrine of Equivalence.



BGH X-ZR 33-88 (1989)

Bundesgerichtshof



# Dependent inventions

Direct and indirect dependencies of patents

**Dominating elder patent:**  
**Mounting element,**  
e.g. example: a nail

**Younger patent:**  
**Use of screws as mounting**  
**elements**

## **Direct dependency**

Not mentioned literally in the elder patent, but covered by the generic term.

**Dominating elder patent:**  
**Use of nails as mounting**  
**elements**

**Younger patent:**  
**Use of screws as mounting**  
**elements**

## **Indirect dependency**

Abstraction of the feature of the elder patent leads from "nails" to "mounting elements"...

... given that an expert knows that both work in the same way !



# Dependent inventions

## Direct dependency

### Legal basis

#### Schließfolgeregler (Locking relais) (1998)

The patent covered a device for controlling the locking system of a two-winged door comprising various features. The alternative made use of all features with the exception of one: the control element of the relais was improved leading to a better stability.

#### Decision of the Oberlandesgericht Düsseldorf

1. For equivalence at first instance it does not matter whether the alternative embodiment has inventive quality, as long as said alternative solves the same problem and makes use of the teaching of the dominating patent.

2. Since the patent claim comprised all relevant features in the form of generic terms only, it has been obvious for one skilled in the art to find an alternative for the control element which was not literally mentioned in the specification, but worked in the same way.

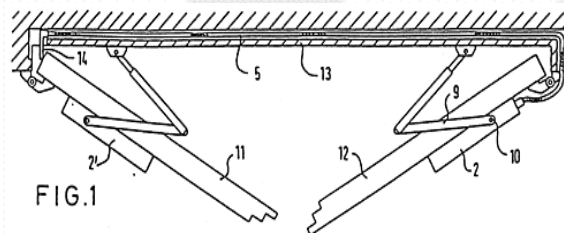





## 1.3. Out of the claims and not equivalent

# Dependent inventions

## Indirect dependency

### Legal basis

#### Befestigungsvorrichtung II (Mounting device) (1990)

The patent covered a framework made of separately connected profile bars with longitudinal slots and hollow sections for engagement of a coupling member in their face ends, useful for stands at a trade fair; main claim 8 included 8 features. The alternative embodiment made use of 7 of these features, while the last feature was used in a specific way, which was not literally mentioned in the specification, but was covered by the generic term.

#### Decision of the Bundesgerichtshof

1. A patent infringement under the Doctrine of Equivalence takes place in case a concrete embodiment of one or more of features of the claim represents a more specific alternative to a generic term which at the time the patent was filed has been identifiable as working in the same way.
2. A development may be considered simultaneously to be inventive and -being a dependent invention – to be encompassed by the scope of protection of an elder patent.
3. In the present case, the feature under consideration has been abstracted to a generic term which also covered the alternative embodiment.

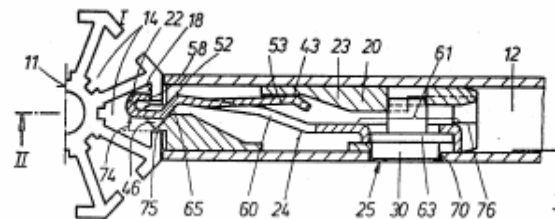

BGH X-ZR 121-88 (1990)  
Bundesgerichtshof



**FAIRTRADE**

Guarantees  
a **better deal**  
for Third World  
Producers



## 1.3. Out of the claims and not equivalent

# Inventive alternatives

The “underlying” problem makes the difference

## Legal basis

### Zerlegevorrichtung für Baumstämme (Fragmentation device) (1994)

The patent covered a fragmentation device for trunks for producing timber beams by using a chain saw blade. The alternative was also protected by a patent, but using a planer instead of the chain saw. The invention solved the problem of reducing waste material by producing a secondary product (shavings) which can be used for flake boards.

#### Decision of the Bundesgerichtshof

1. In case a direct dependency does not exist, the scope of protection a claim provides does not encompass equivalent solutions, which are based on an inventive step.
2. In the concrete case chain saw blades and planers do not represent alternatives working the same way, since the alternative solves a different problem.
3. Modifying the problem underlying the invention in a patentable way leads out of the scope of protection of the elder patent; an equivalence does not exist.



BGH X-ZR 16-900 (1994)  
Bundesgerichtshof

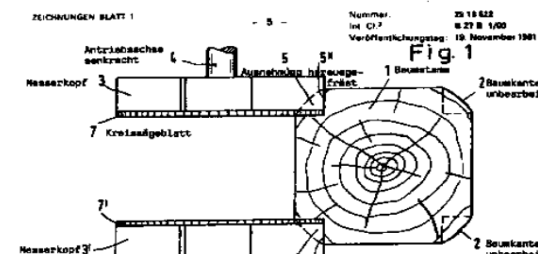



## 1.3. Out of the claims and not equivalent

# Inventive alternatives

The “underlying” problem makes the difference (2)

## Legal basis

### Räumschild (Dozer blade) (1999)

The patent concerned a clearing strip for the clearing shield of a snow-plough, consisting of a rubber or plastic body (4) which was reinforced on both sides on the surface with steel plates (1, 2) and in which highly wear-resistant hard-material balls were embedded, for improving the flexibility of the blades.

The alternative was also patented, but used similar blades in which instead of hard metal balls hard metal sticks were embedded in order to increase stability.

### Decision of the Bundesgerichtshof

1. A precondition for making use of a patented technical teaching by a younger, depending invention is that the claims comprise all features of the dominating patent either literally or under equivalence, in order to establish a new teaching which one skilled in the art can understand to work in the same way.

2. In the present case it is not admissible to abstract „hard-material balls“ in order to create a broader generic term which would also encompass „hard-material sticks“, since one skilled in the art would not necessarily understand that one can exchange „balls“ by „sticks“ to solve the new problem.

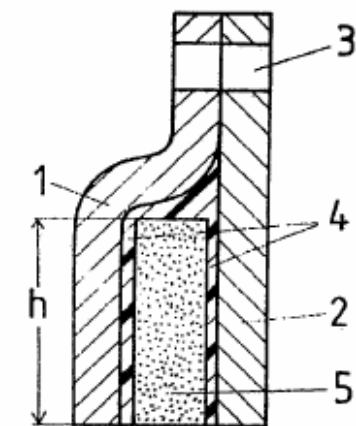

BGH X-ZR 156-970 (1999)

Bundesgerichtshof





## 1.3. Out of the claims and not equivalent

## Deteriorated embodiments

No resurrection of the Lindenmeier Doctrine

### Legal basis

#### Spannschraube (Clamping screw) (1999)

The patent covered a pipe clamp, comprising an annular strap with at least one opening which can be closed by a clamping screw, which was characterised that said clamp was fitted to a flat washer. The flat wash allowed to use also extremely short screws without losing stability.

The alternative embodiment was represented by the same pipe clamp and the same clamping screw, however, without said flat washer.

#### Decision of the Bundesgerichtshof

1. The scope of protection a patent provides cannot be enlarged to embodiments representing alternatives which completely or to a serious extent waive to establish the success associated with the patented invention.

2. Deteriorated embodiments outside of the literal wording of the claims are not encompassed by the Doctrine of Equivalence.

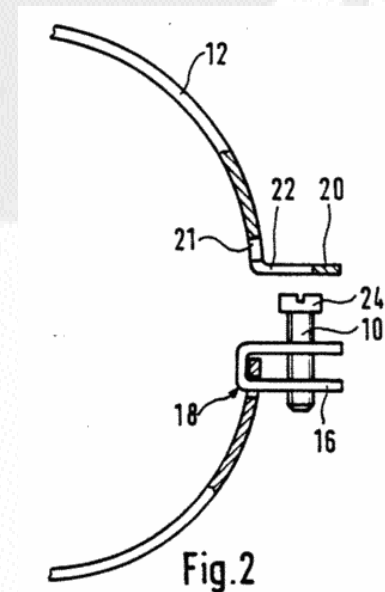

BGH X-ZR 85-96 (1999)

Bundesgerichtshof



# Numbers and numerical ranges

## Ancient decision of the interpretation of numerical ranges

### Legal basis

#### Bierklärmittel (Fining agents for beer) (1984)

The patent covered a fining agent for beers which was characterised by a content of a silica gel exhibiting an inner surface of 200 to 400 m<sup>2</sup>/g.

The difference between the patented invention and the allegedly infringing alternative was that the inner surface of the copy showed a value of about 500 m<sup>2</sup>/g.

#### Decision of the Bundesgerichtshof

1. The novelty of the patented invention was essentially connected to the defined range for the inner surface of the fining agent. One skilled in the art has not been able to recognise that also silica gel showing a higher inner surface than claimed solves the problem in the same way and with the same success.

2. An infringement under Doctrine of Equivalence was therefore denied.



BGH X-ZR 7-82 (1984)

Bundesgerichtshof





# Judex non calculat

A judge does not count ... or does he?

## Legal basis

### Entscheidungsquintett of 2002 („Quintet of decisions“)

In 2005 German Supreme Court issued 5 decisions concerning the interpretation of numbers and numerical ranges establishing a three-step algorithm for applying the Doctrine of Equivalence:

- Schneidmesser I (Cutting knife)
- Schneidmesser II
- Custodiol I
- Custodiol II
- Kunststoffrohrteil (Polymer piping component)

### Interpretation of numbers and numerical ranges

The court emphasised that basically also numbers and numerical ranges are open for interpretation. The so-called „Cutting Knife Questions“ for proof on equivalence were formulated in analogy to the British so-called „Improver or Protocoll Questions“.



Bundesgerichtshof







# Numbers and numerical ranges

## Importance of tolerances and standards

### Legal basis

#### Schneidmesser I (Cutting knife I) (2002)

A first object of German patent DE 3719721 C2 has been a rotating knife for rotating cutting devices in paper industry showing a first cutting angle  $A$  of 9 to 12°.

The alternative has been a similar device showing a first cutting angle  $A$  of 8°40 min, while the tolerance according to a respective DIN standard has been 20 min.

#### Decision of the Bundesgerichtshof

1. The scope of protection a patent provides is defined and therefore also limited by numbers and numerical ranges. Like any other part of a claim, however, these features are open for interpretation. In case it is not obvious for one skilled in the art that also values outside of the literal wording of the claims solve the underlying problem in the same way, the scope of protection is limited to the claim language.
2. However, tolerances – especially those provide by industrial standards – are well known to everyone skilled in the art. Adding the tolerance to the lower limit of the claim moves the alternative into the literal wording of the patented invention. Therefore, direct infringement is concluded.



BGH X-ZR 168-00 (2002)

Bundesgerichtshof

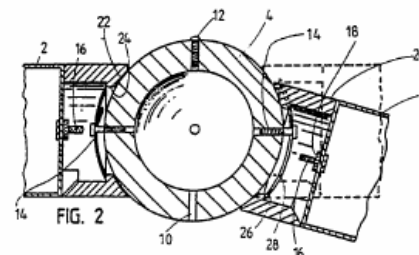



# Numbers and numerical ranges

## Importance of what the specification teaches

### Legal basis

#### Schneidmesser II (Cutting knife II) (2002)

Another object of German patent DE 3719721 C2 has been a rotating knife for rotating cutting devices in paper industry showing a second cutting angle B of 1 to 22, preferably 16°.

The alternative has been a similar device showing a second cutting angle B of 26°.

#### Decision of the Bundesgerichtshof

1. In case the claims of a patent stay beyond the technical teaching as provided by the specification, its scope of protection also encompasses those embodiments which one skilled in the art could have identified as being working in the same way and providing the same results.
2. The specification was silent with respect to any teaching according to which same results could also be achieved by using cutting angles of more than 22°. In the alternative it was pointed out that the preferred angles can be found at lower values.
3. Therefore, an infringement under Doctrine of Equivalence was denied.



BGH X-ZR 135-01 (2002)

Bundesgerichtshof

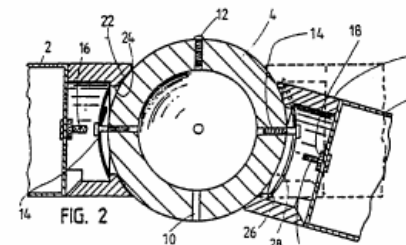



## 1.4. On the knives edge – Landmark decisions from 2002

# Numbers and numerical ranges

No distinction between important and less important features

## Legal basis

### Custodiol I + II (2002)

Object of the German part of European patent EP 0054635 B1 has been a pharmaceutical composition for protecting organs after surgery comprising a multitude of components.

The alternative differed from the composition as claimed in that its content of magnesium chloride was 4 mmol/l instead of 8 to 12 mmol/l.

### Decision of the Bundesgerichtshof

1. Nothing in the specification could serve as a basis for one skilled in the art to understand that the numerical ranges given in the claims are not critical, but serve as an example.
2. Features in a claim need to be taken as they are; there is no basis to distinguish between „important“ and „less important features“
3. Therefore, an infringement under Doctrine of Equivalence was denied and the request to issue a Supplemental Protection Certificate covering the alternative was rejected.

Kalium- oder Natrium-hydrogen- o-ketoglutarat	4 ±	3 Millimol
Natriumchlorid	15 ±	8 Millimol
Kaliumchlorid	10 ±	8 Millimol
Magnesiumchlorid	10 ±	2 Millimol
Tryptophan	2 ±	1 Millimol
Histidin	150 ±	100 Millimol
Histidin-Hydrochlorid	16 ±	11 Millimol
Mannitol	50 ±	50 Millimol
Fruktose	50 ±	50 Millimol
Ribose	50 ±	50 Millimol
Inosin	50 ±	50 Millimol



BGH X-ZR 73-01 (2002)

Bundesgerichtshof







## Numbers and numerical ranges

Prosecution history estoppels – a US phenomena



“

Every amendment of the claims which leads to a limitation of the scope of protection effects prosecution history estoppel.

In case PHE is effected for a specific feature, the Doctrine of Equivalence is not longer available.

In Re Festo

”



# Numbers and numerical ranges

## No prosecution history estoppels

### Legal basis

#### Plastikrohrteil (Polymer piping components) (2002)

Object of the German part of European patent EP 254375 B1 has been a waste pipe system of an injection moulded or extruded pipe part of thermoplastic material having a weight per unit area of at least  $8 \text{ kg/m}^2$ . The density of the plastic pipe part was defined being 1.8 and 2.7, preferably between 1.8 and  $2.0 \text{ g/cm}^3$ . The density feature was introduced during the opposition procedure

The alternative has been a similar device, however showing a density of  $1.6 \text{ g/cm}^3$ .

#### Decision of the Bundesgerichtshof

1. In case the technical teaching of the patent does not go beyond what is defined in the claim and there is nothing what one skilled in the art would recognise that the technical success can also be achieved outside of the numerical ranges as claimed, the scope such patent enjoys is limited to the claim language.
2. For the application of the Doctrine of Equivalence file history is not relevant.
3. Since the patent did not provide any information that even a lower density of  $1.6 \text{ g/cm}^3$  would work in the same way, any infringement under the Doctrine of Equivalence was denied.



BGH X-ZR 43-01 (2002)

Bundesgerichtshof





# The Cutting Knife Questions

Three-step algorithm for proof on Doctrine of Equivalence

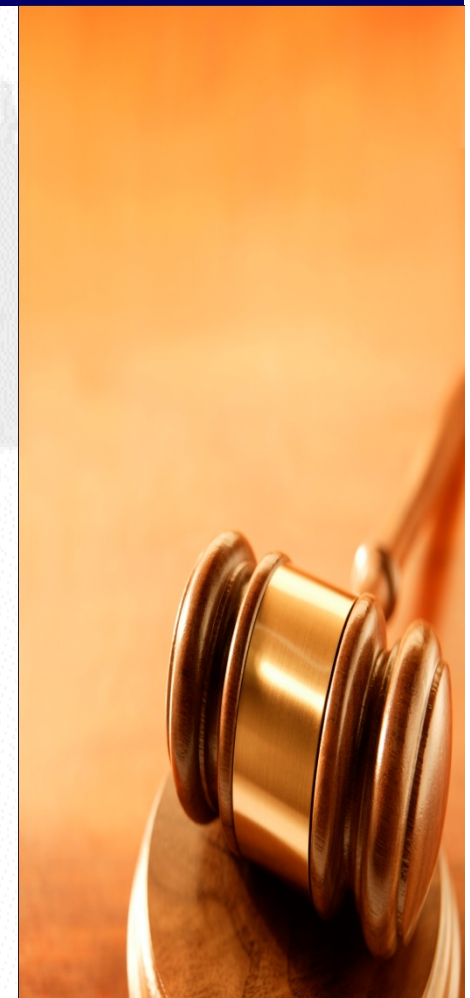
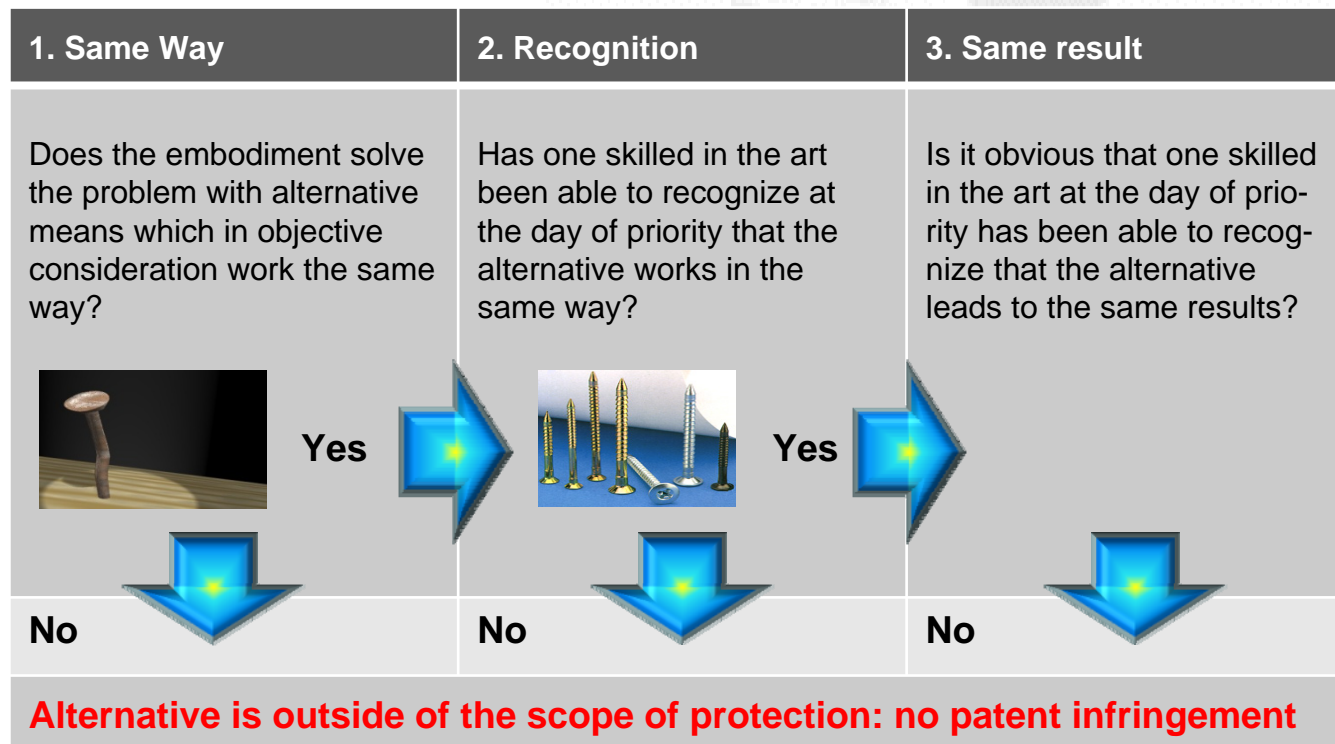





# 135 years of literal scope of protection

Landmark decision EMI vs. Linssen (1930)

A claim is a portion of the specification which fulfils a separate and distinct function. It, and it alone, defines the monopole.

Lord Cairns (1877)

The function of the claims is to define clearly and with precision the monopoly claimed. Their primary object is to limit and not to extend the monopoly. What is not claimed is disclaimed.

Lord Russel (1930)





# Pith & Marrow

... but there has always be some protection outside of the claims

## Legal basis

### Van der Lely vs. Bramford (1963)

The patent covered a machine to turn hay balls around, consisting of a multitude of features. The infringing embodiment used exactly the same machine, however, with a slight difference in a single feature.

#### Decision of the House of Lords

1. Although British Courts typically limit the scope of a claim to its language, Case Law always provides protection beyond the literal wording of the claim. In particular in those cases, where the infringing alternative differs only in minor parts from what is covered by the claims as granted.

2. In the course of the so-called „Pith & Marrow Doctrine“ an infringement was constituted.

**„There is some illogicality, but our law has always preferred good sense to strict logic.“**

Lord Reid







## 1.5. Great Britain – Different view of the same topic

# Purposive Construction

... but there has always be some protection outside of the claims

## Legal basis

### Catnick vs. Hill-Smith (1980)

The Catnick patent covered a window lintel which was characterised in that an additional shield plate was adjusted horizontally (= 90°) to said lintel.

Hill-Smith had used identical window lintels for quite a time and changed the design after they received a warning letter from the patent proprietor. Now the shields were adjusted to the lintel in an angle of 82 to 86°.

### Decision of the House of Lords

1. A patent specification is a unilateral statement by the patentee. In words of his own choice, addressing to those skilled in the art, by which he informs them what he claims to be the essential features of the new product or process for which the letters patent grants him a monopoly.
2. A patent specification should be given a purposive construction rather than a purely essential one derived from applying to it the kind of meticulous verbal analysis in which lawyers are too often tempted to their training to indulge.
3. Patent infringement was confirmed. (Lord Diplock)

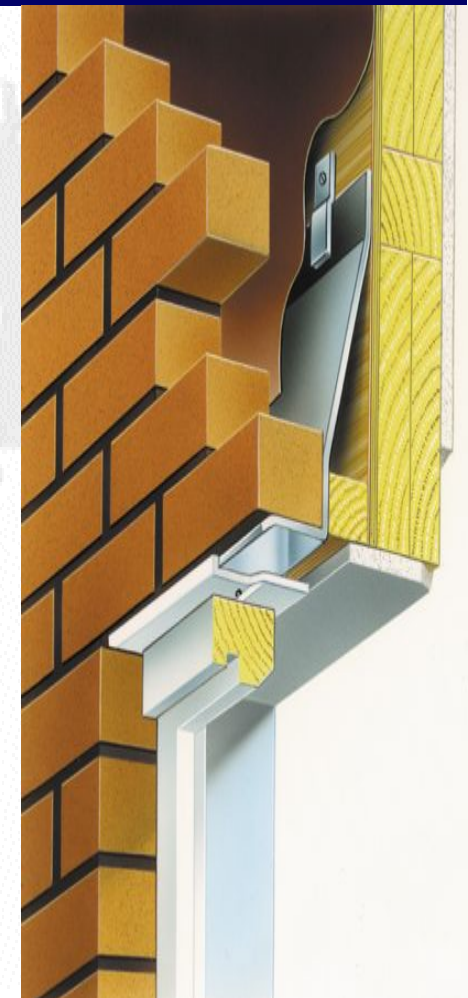





# The Protocol Questions

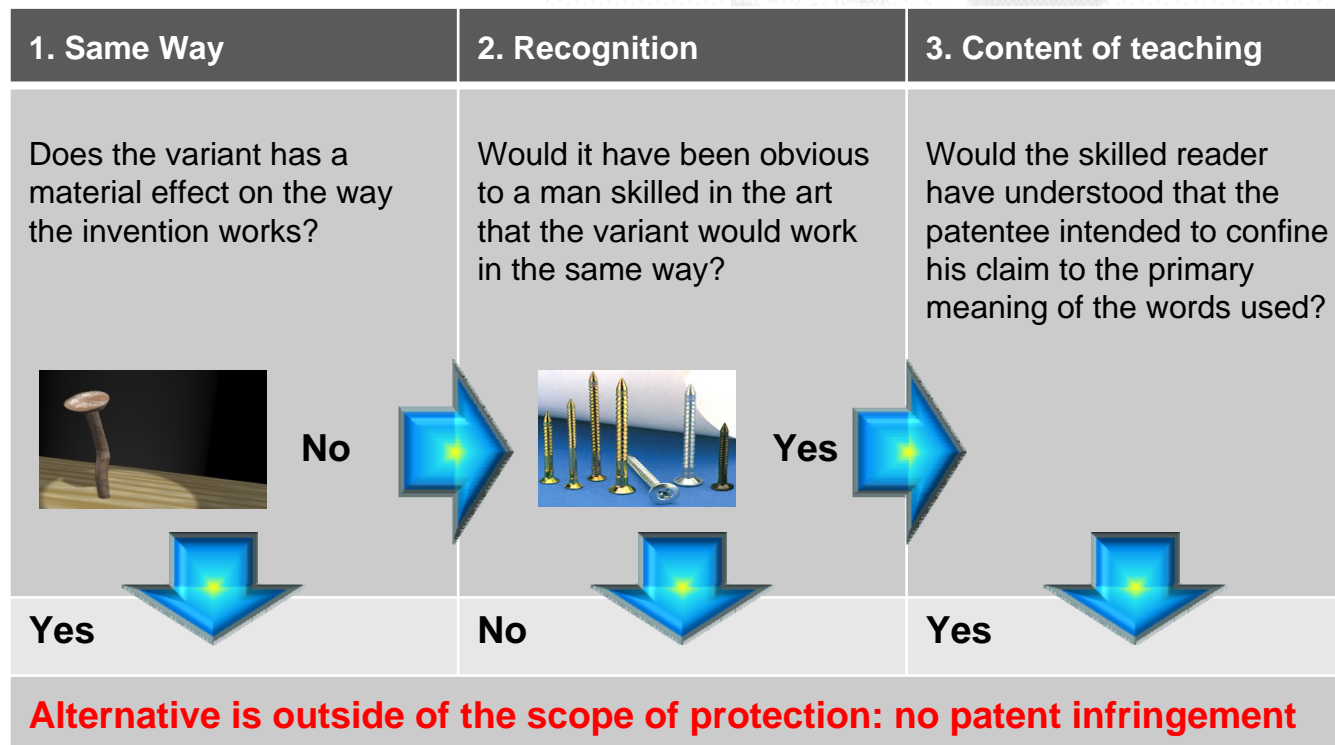

Three-step algorithm for proof on Doctrine of Equivalence



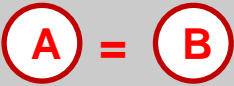
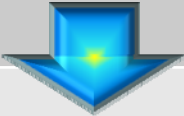

# Cutting knife vs. Protocol Questions

Differentiation only in the third question

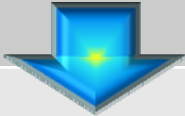
Germany : 3. Same result	Great Britain: 3. Content of teaching
<p>Is it obvious that one skilled in the art at the day of priority has been able to recognize that the alternative leads to the same results?</p> <p style="text-align: center;">  </p> <p style="text-align: center;">  </p>	<p>Would the skilled reader have understood that the patentee intended to confine his claim to the primary meaning of the words used?</p> <p style="text-align: center;">  </p> <p style="text-align: center;">  </p>
No	Yes
<p><b>Alternative is outside of the scope of protection: no patent infringement</b></p>	





## 1.5. Great Britain – Different view of the same topic

# Epilady ... The things of shave to come

## Public interest dominates claim for broad protection

### Legal basis

#### Improver vs. Remington (1990)

The Improver patent referred to a device for depilation of female body hairs by means of a rotating, helical shaped blades ("Epilady"), while the alternative ("Lady Remington" achieved the same result by using a rubber ball with slots.



#### Decision of the House of Lords

1. The variant did not have a material effect on the way the result was achieved: instead of shaving the body hair it was plugged out. At the day of priority one skilled in the art was also able to recognise that the variant would work in the same way.

2. However, since public had no reason to doubt that patentee has chosen the wording of the claim with good reason patent infringement under the Doctrine of Equivalence was denied. (Lord Hoffmann)

## Süss, sanft und effektiv

Auf den ersten Blick erinnert die Haarentfernung mit Zucker an das weit verbreitete Wachsen: Eine klebrige Paste wird aufgetragen und wieder abgezogen. Die süsse Variante hat jedoch einige Vorzüge zu bieten

Die reizarme Haarentfernung mit Zuckerpaste eignet sich auch sehr gut für die Bikini-Zone







1.5. Great Britain – Different view of the same topic

# Epogen

Doping for the British patent system

## Kirin-Amgen Process

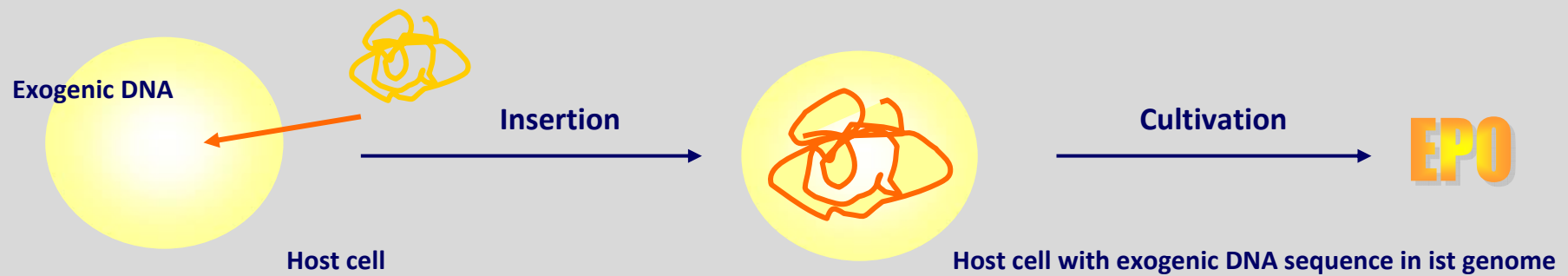

## Hoechst-TKT Process

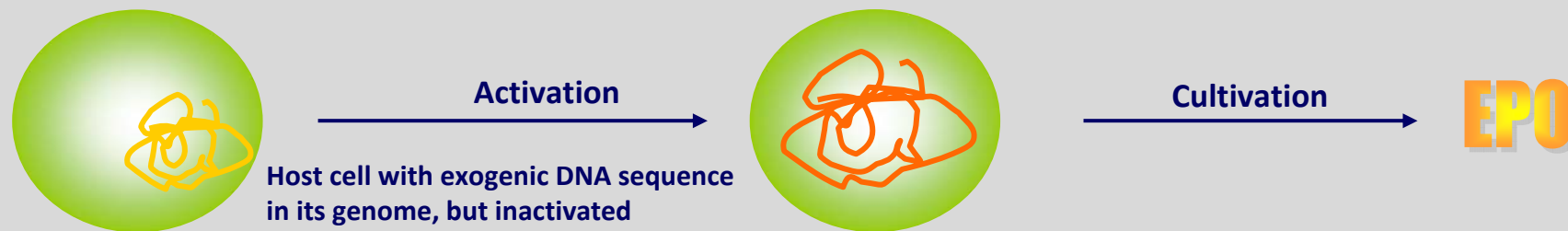



## 1.5. Great Britain – Different view of the same topic

# Epogen

## Three decisions – three argumentations – one result

### Legal basis

#### **Kirim Amgen vs. Hoechst TKT (1990)**

Epogen is the brand name for Erythropoietin, a glycoprotein, that is produced in human kidneys and is responsible for the production of red blood cells and therefore is important for oxygen transport in blood. In medicine it is administered after surgery – but is better known from blood doping.

Kirim Amgen has been proprietor of European patent EP 0148605 B1 of 1983, which has expired in 2004. Corresponding patents existed all over the world. The company sold Epogen for many years in Europe. The competitor TK launched the similar product (“Dynepo”), which was produced according to a different process.

EPO is not covered by an product claim and parties agreed that the process for obtaining the product were of course different. However, Kirim Amgen sued TKT in many countries for alleged infringement under Doctrine of equivalence – with very different results.

#### Decisions up to the House of Lords

1st Instance: Infringement of independent Claim 1 (recombined protein), but claim invalid due to insufficient disclosure. Independent Claim 28 (polypeptide) valid, but no infringement.

2nd Instance : Both claims 19 and 26 were regarded valid, but no infringement

3rd Instance: Claim 19 insufficient disclosed, Claim 26 not novel, no infringement of any claim. (Lord Hoffmann, House of Lords)





# Epogen

Good-bye for Improver questions ?

“

The Improver Questions represent non-binding guidelines for determining the scope of protection of a patent; one might apply them, but it is not mandatory. The application of the Improver Questions for determining technologies, which were not available at the governing point in time, is not admissible. The key question remains, how one skilled in the art would understand the wording of the claim. This typically must lead to a narrow interpretation.

”



Lord Hoffmann (199)





# Contributory Infringement

From historic case law to § 10 PatG

Essential elements of an invention and their functional co-operation

Right time for infringement

Case Study Example

Damages

Contributory Infringement outside the borders





2. Contributory Infringement

# Contributory infringement ...

A direct business risk but almost unknown to business people

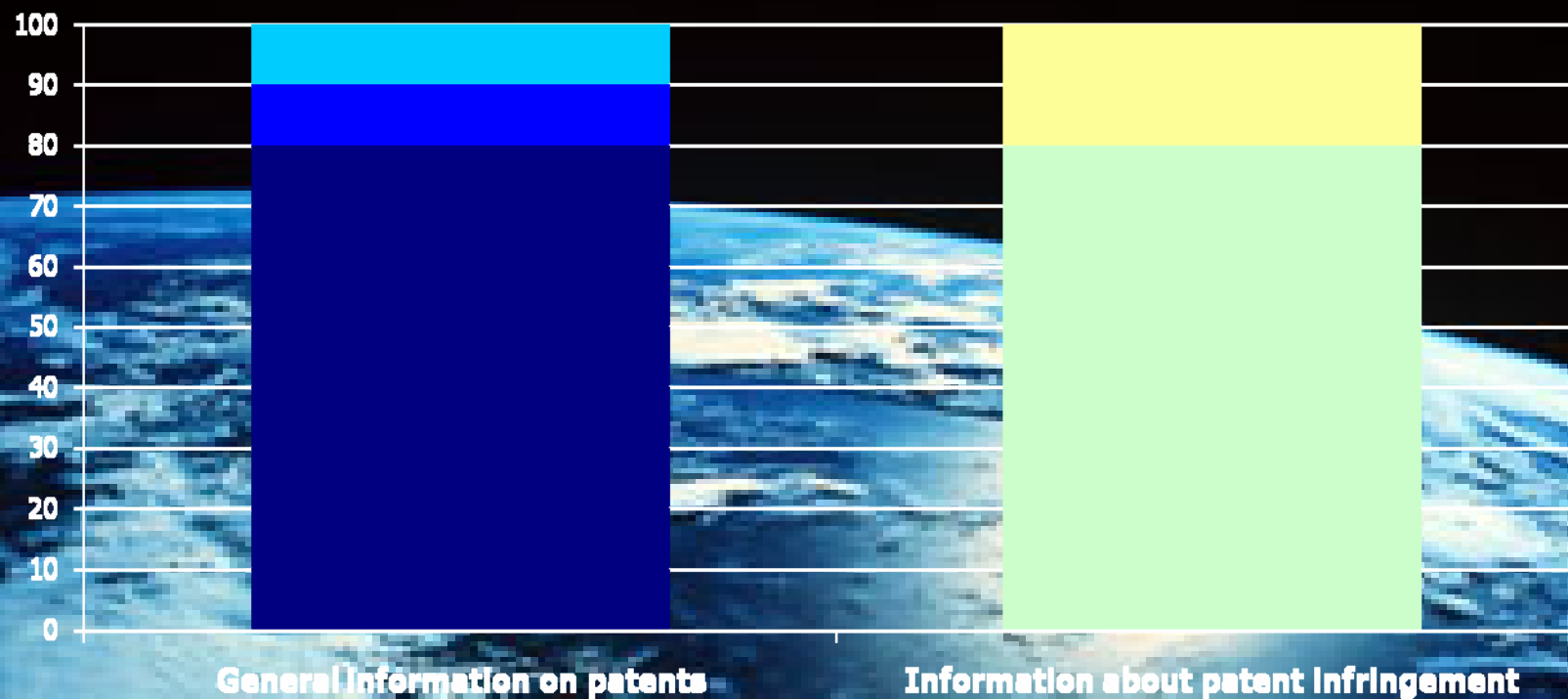

- Feel myself well informed
- Would need more information
- No response
- Direct infringement well known
- Doctrine of equivalence means something to me
- Contributory infringement known



## Effect of a patent

Right to use versus prohibition right - § 9 German Patent Law

“

A patent effects that only the patent proprietor is entitled to Make use of the patented invention. Without the permission of the patent proprietor any third party is forbidden ...

- ... to produce, offer or sell a product which is object of the patent ...
- ... to make use of a process which is object of the patent within the territory in which the patent is valid,
- ... to offer or sell a product representing the direct result of a process which is object of a patent (...).

”







## 2. Contributory Infringement

# Effect of a patent

Right to use versus prohibition right - § 10 German Patent Law

“

In addition, a patent encompasses also the effect, that without permission of the patent proprietor every third party is forbidden (...) to offer or supply products, referring to an essential element of an invention to third parties acting without permission of said patent proprietor, on condition that supplier **knows or under the given circumstances had to expect** that said products are intended for abuse of the patented invention. This clause is not applicable for those products **representing common products well known in the market for the respective purpose.**

”





2. Contributory Infringement

# Contributory infringement

Decisions from the Federal Supreme Court (BGH) year by year

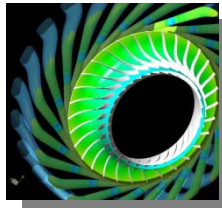

2004  
**Flügelradzähler  
(Impeller counter)**  
Essential elements of inventions  
And exhaustion of patent rights

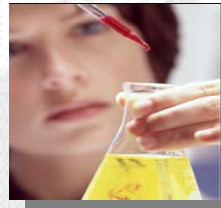

2007  
**Pipettensystem  
(Pipette system)**  
Essential elements of an invention  
and exhaustion of patent rights

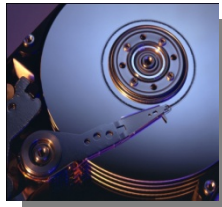

2005  
**Antriebsscheibenaufzug  
(Traction sheave elevator)**  
Damages and compensation



2007  
**Haubenstretchautomat  
(Automatic stretch hood)**  
Cease and desist declaration  
under penalty of law and  
compensation

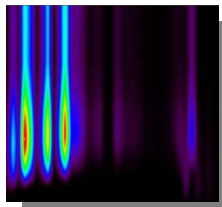

2006  
**Deckenheizung  
(Overhead heat)**  
Patent threat element



2007  
**Rohrschweißverfahren  
(Pipe bonding process)**  
Essential elements of inventions



2007  
**Funkuhr II (Radio clock II)**  
Delivery from overseas and  
unjustified warnings

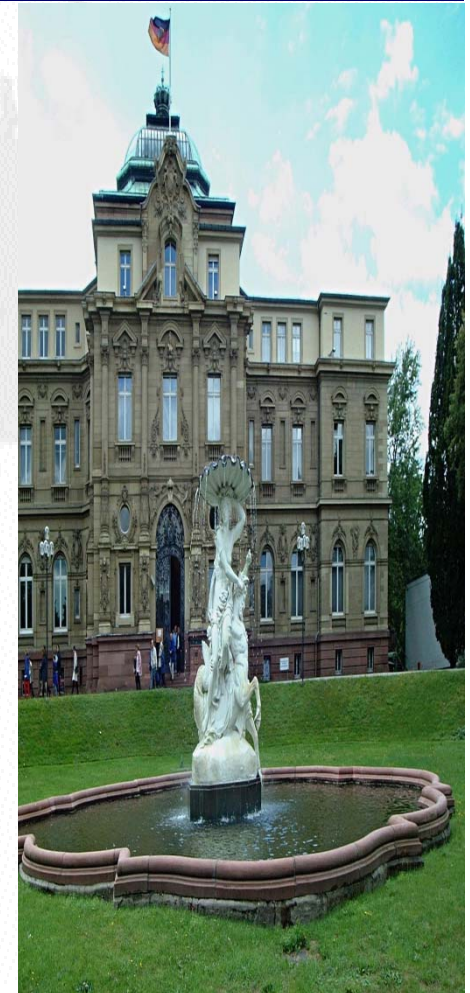



## Essential elements and exhaustion of the invention

Is replacement equal to new manufacturing?

### Legal basis

#### Flügelradzähler (Impeller counter) (2004)

The respective patent was directed to a device for counting water consumption, consisting of a specific container and a convertible measuring capsule. Defendent offered and sold said measuring capsules perfectly fitting into the specific containers. Therefore, patentee sued supplier for alleged contributory infringement.

#### Decision of the OLG Frankfurt (1st instance)

1. The objected measuring devices are not subject of the patent and do not represent essential features of the invention, since the inventive step of the patent was linked to special shape of the container.
2. The replacement of convertible and highly expendable elements of the patented device represents a permitted use in the sense of a repair; therefore exhaustion of the patent right has taken place.

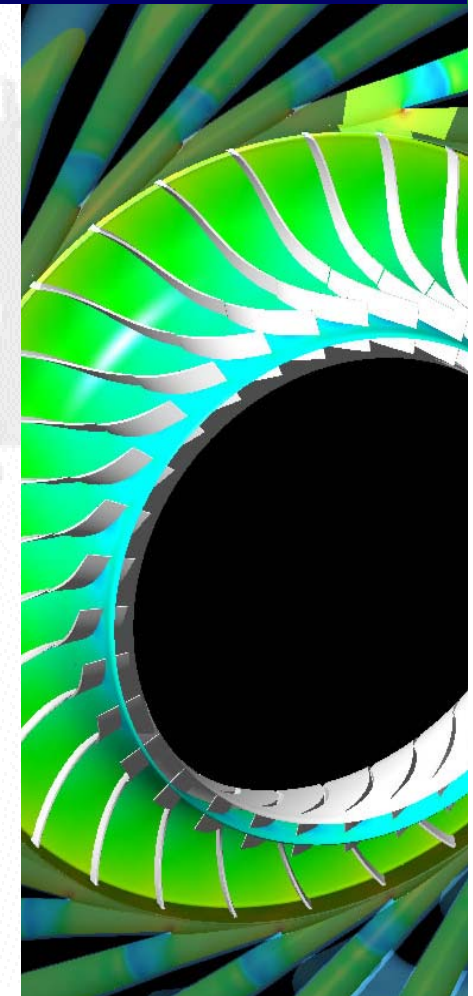
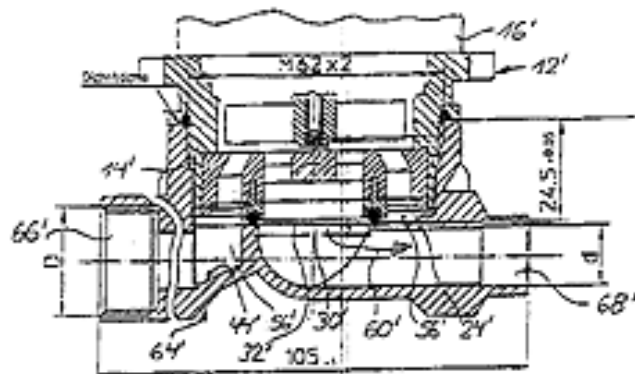





# Essential elements and exhaustion of the invention

## Federal Supreme Court disagrees and sets standards

### Legal basis

#### Flügelradzähler (Impeller counter) (2004)

##### Decision of the Bundesgerichtshof

1. According to § 10 PatG a means refers to an essential element of an invention in case it is suitable for functional interaction of one or more features of the patent claim in order to implement the protected technical teaching.

Only features not fulfilling this condition can be disregarded.

1. Whether or not the replacement of a specific part of a means is equal to a new manufacturing of the device depends on the balance between the right of the patentee for protection of the patented invention and the need for the consumer to have unlimited access to use the respective device.



BGH X-ZR 48/03 (2004)

Bundesgerichtshof

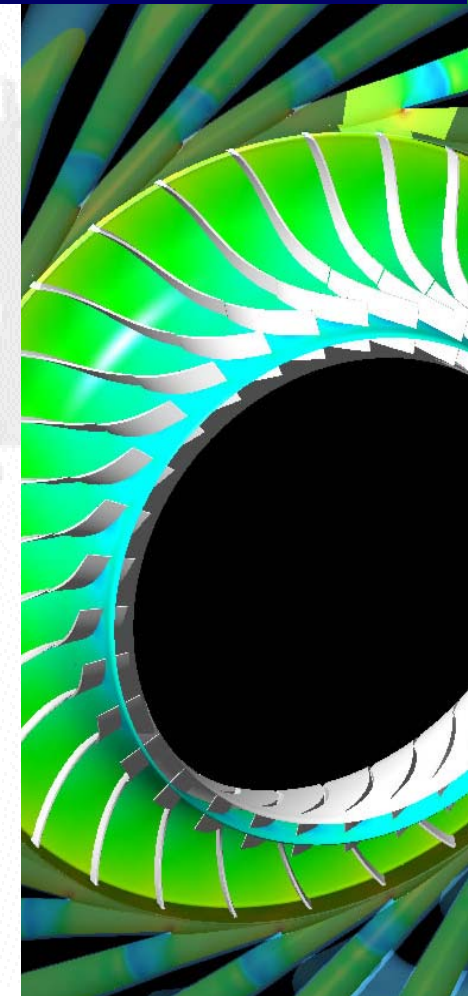



## Essential elements and exhaustion of the invention

Exhaustion depends how often parts of a device are scheduled for replacement

### Legal basis

#### Pipettensystem (Pipette system) (2007)

The respective patent was directed to a device consisting of a fixing device and an ejector for one-way pipettes.

A producer of standard pipettes advertised his products with a comment according to which they would also fit into the patented device.

Subsequently, patentee sued the producer for alleged contributory infringement.

#### Decision of the Bundesgerichtshof

1. In the sense of § 10 PatG a feature of a patent claim does not represent an essential element of the invention, in case said element does not contribute to the solution to the problem underlying said invention. In the present case, without pipettes the device would not work, therefore the pipettes re-present essential elements of the invention.

2. For distinguishing between a permitted exchange and a non-permitted new manufacturing of an element which is subject of the invention it is mandatory to determine, whether or not such replacement comes close to the creation of a new device. In the present case, to consider every replacement of a one-way pipette as a new creation of the device would mean to encompass the pipettes into the scope of protection the patent provides, which would be inadmissible.



BGH X-ZR 38/06 (2007)

Bundesgerichtshof

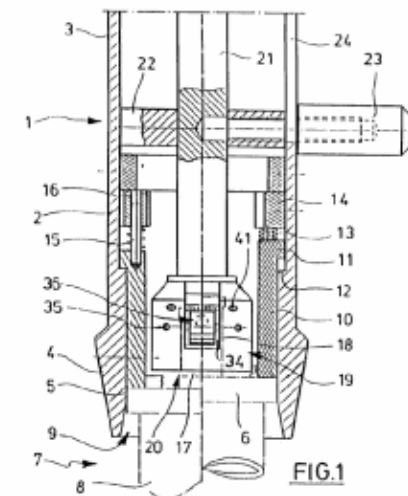



# Essential elements and exhaustion of the invention

Standards count also for process inventions

## Legal basis

### Rohrschweißverfahren (Pipe bonding process) (2007)

The object of the invention has been a process for automatic bonding of pipes by means of a software program steering the bonding machine.

#### Decision of the Bundesgerichtshof

1. In case a process claim makes reference to a device for use in the protected process, such device always represents an essential element of the invention.
2. In case a bonding process encompassing several process steps according to which in a first step a data medium comprising the relevant process information is produced and in a second step said data medium is used for steering the bonding machine, one using the data medium makes use of all features of the claims of the patented invention.
3. Without permission of patentee the supply of a data medium comprising the relevant bonding information establishes a case of contributory patent infringement.



BGH X-ZR 113/04 (2007)

Bundesgerichtshof

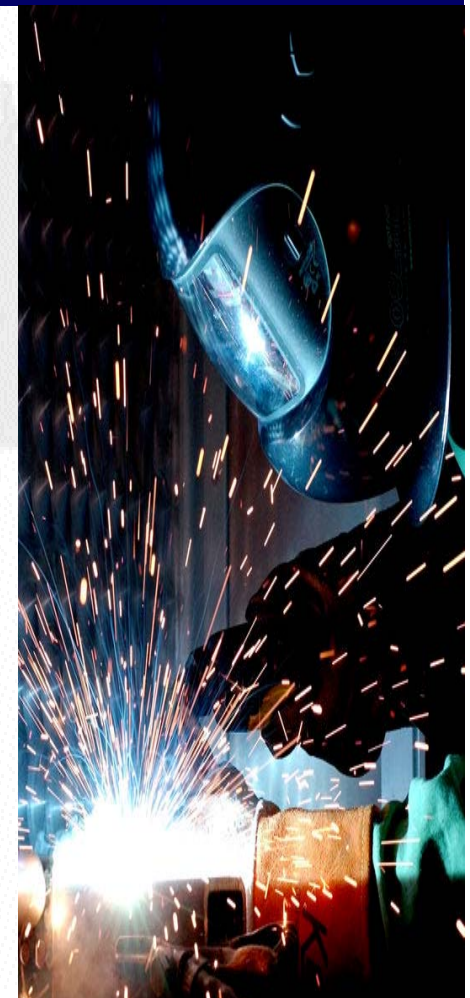





## Example: Composition of a cosmetic

Does the well-known thickener polyacrylate represent an essential element of the invention ?

### Creme showing increased sensory feeling

Avocado Oil (Oil body)



Stearyl glucoside (Emulsifier)



Polyacrylate (Thickener)



Glycerol



Dyes and perfumes



Without thickener



With thickener





## Lessons learned

### Essential elements and exhaustion

“

**For contributory infringement only essential elements need to be taken into consideration. A feature is essential in case it is suitable to interact with other features of the patented invention in order to achieve the desired result. In other words: to renounce from an essential element means that the invention would not work any longer.**

**To determine whether or not the exchange or repair of an essential element is permitted in the sense of exhaustion of the invention depends on the fact, whether it lies in the nature of the patented invention that such exchange or repair takes place often.**

”





## 2.2. Time and conditions for contributory infringement

# Time and conditions

What is necessary to establish a case of contributory infringement?

### Legal basis

#### Deckenheizung (Overhead heat) (2006)

The respective patent was directed to an overhead heat consisting of metal plates suitable for heating or cooling, which were assembled in a sort of mats, while the thermic fluid was lead through a pipe system. After the termination of a cross-license agreement the defendant continued to offer the respective pipe systems for use in the protected overhead heats. Subsequently, the supplier was sued for alleged contributory infringement.

#### Decision of the Bundesgerichtshof

1. The fact of a contributory infringement does not require the decision of a customer to purchase the offered good in a way a third party's patent is violated.

2. In contrast it is sufficient that supplier has positive knowledge or under the given circumstances should have known that the customer intends to use the offered goods in a manner that a third party's patent is infringed.

Consequently, contributory infringement does not require a direct infringement. To offer a good suitable for functional interaction with other elements of a patented invention can already establish a case of contributory infringement.



BGH X-ZR 153/03 (2006)

Bundesgerichtshof

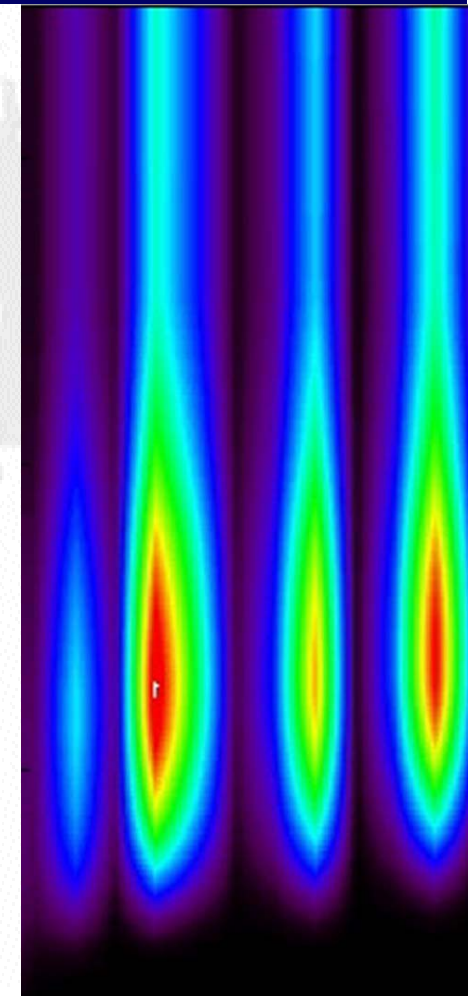





# Case Study

Pt/Pd storage for fuel cells

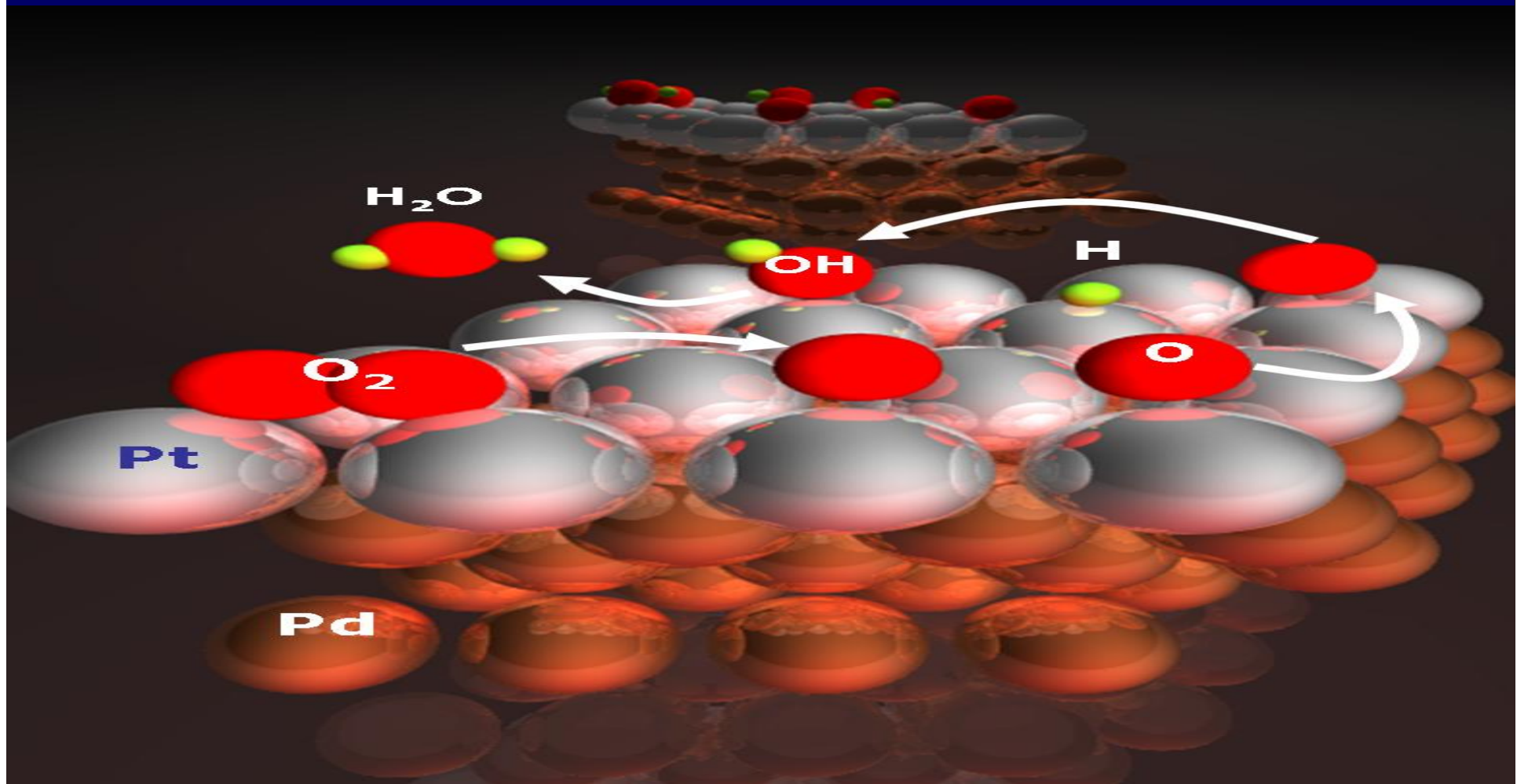



## 2.3. Case Study

# Direct or contributory infringement ?

Joint tortfeasorship

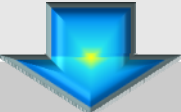
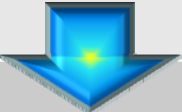
Protection for Patentee A „Fuel cells comprising one or more Pt/Pd hydrogen storage units“	
Producer of fuel cells B	Producer of Pt/Pd H <sub>2</sub> storages C
Uses the Pt/Pd-H <sub>2</sub> -storages for the production of own fuel cells without having a permission or license of A	Offers and sells said Pt/Pd-H <sub>2</sub> -storages to B although knowing that the storages are used for the production of fuel cells.
	
<b>Direct patent infringement § 9 PatG</b>	<b>Contributory patent infringement § 10 PatG</b>

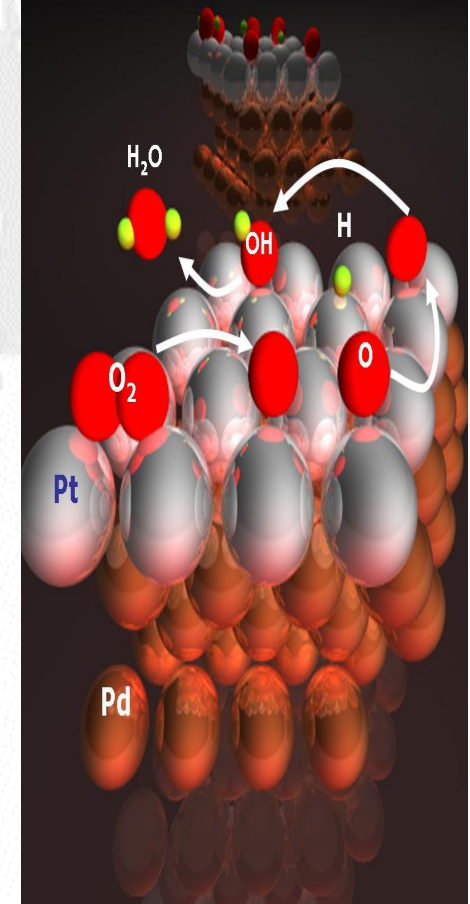



## 2.3. Case Study

# Direct or contributory infringement ?

A question of strategy

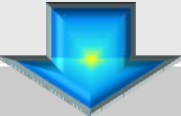
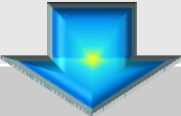
Protection for Patentee A „Fuel cells comprising one or more Pt/Pd hydrogen storage units“	
Sues ...	Sues ...
<p>The producer of the fuel cells, that means the direct infringer: From a strategic point of view disadvantageous: why suing a customer with whom one wants to make money?</p>	<p>The producer of the Pt/Pd hydrogen storages, that means the contributory infringer: Makes sense, since the customer is not under attack, but the competitor is kicked out of the business</p>
	
<b>Very unlikely</b>	<b>Very likely</b>

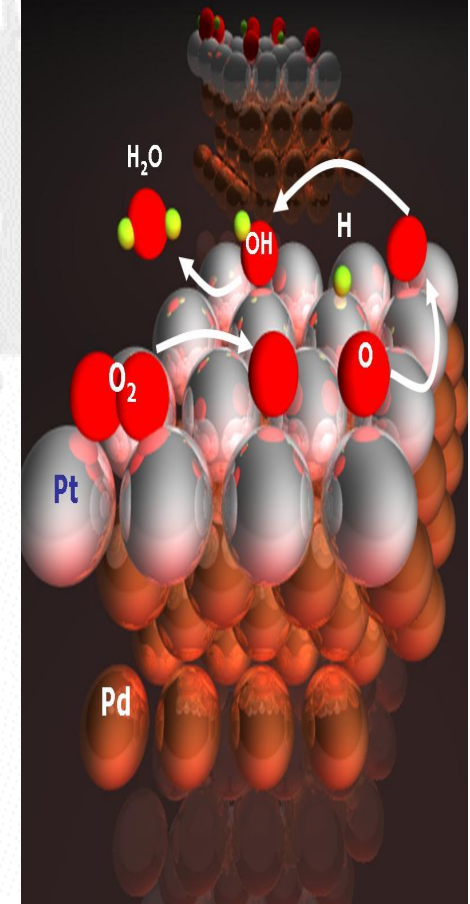



## 2.3. Case Study

# Case alternatives

## High standards for diligence

Supplier C has not have any positive knowledge what his customer B intends to do with the Pt/Pd hydrogen storages, but ...

Pt/Pd hydrogen storages are only useful for the production of fuel cells.

**Patent infringement**



Pt/Pd hydrogen storages are also suitable for other purposes, but of them serve economical purposes.

**Patent infringement**



Pt/Pd hydrogen storages can be used for the production of fuel cells, but also for other purposes which are typical for the customer.

**No patent infringement**



Supplier does not want anything to know about the intended purpose.

**Patent infringement**

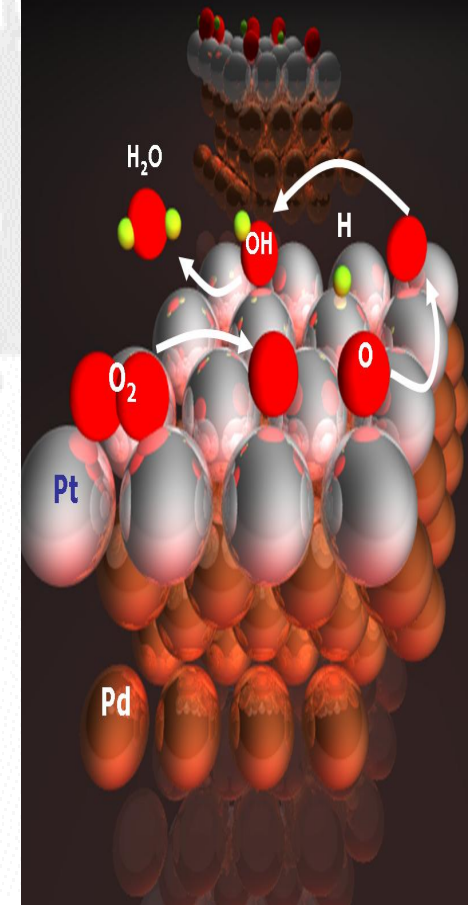





## 2.3. Case Study

# Case alternatives

## High standards for diligence

Supplier C has not have any positive knowledge what his customer B intends to do with the Pt/Pd hydrogen storages, but ...

Pt/Pd hydrogen storages can be used for the production of fuel cells, but also for other purposes which are typical for the customer. In this case suitable measures for additional protection may be:

⇒ Exclusion of liability via General Business Conditions



⇒ Concrete warning advices for blocked applications



⇒ Cease and desist declaration (under penalty of law)

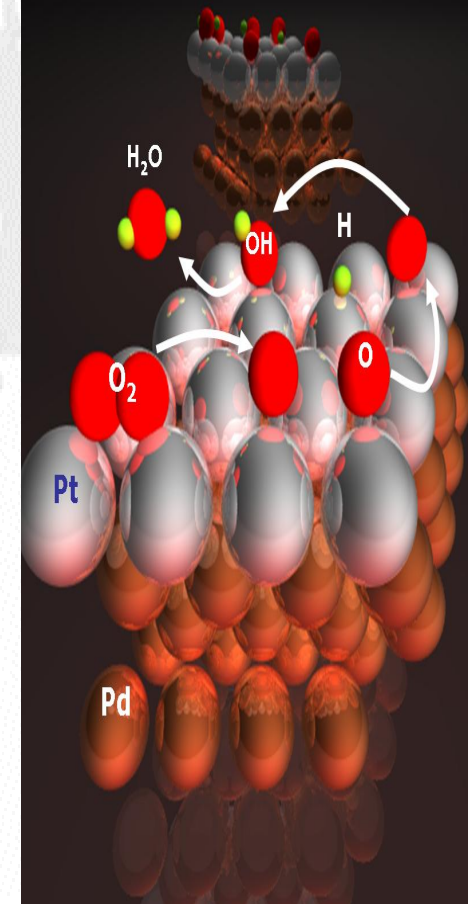



## 2.4. Damages

# Damages

Does a claim for damages require an established case of contributory infringement

## Legal basis

### Antriebsscheibenaufzug (Traction sheave elevator) (2005)

Object of the patent has been drive plates for elevators which could be installed into elevator tubes requiring a minimum of space. The defendant offered and sold the respective drive plates, however, the advertisement encompassed – at least in part – clear warnings with respect to the specific patent of the claimant. Nevertheless, patentee sued supplier for alleged contributory infringement.

#### Decision of the Oberlandesgericht Düsseldorf

1. According to § 9 PatG only the patentee is entitled to allow third parties to make use of the patented invention and to receive royalties therefore. In case the contributory infringer makes it impossible for the patentee to offer and sell its protected goods to the customer, the infringer is liable and has to pay damages, e.g. in the sense of retro-active license fee.

Consequently, the OLG has come to the conclusion that contributory infringer has to pay damages to the patentee even in case that a direct infringement has not taken place.

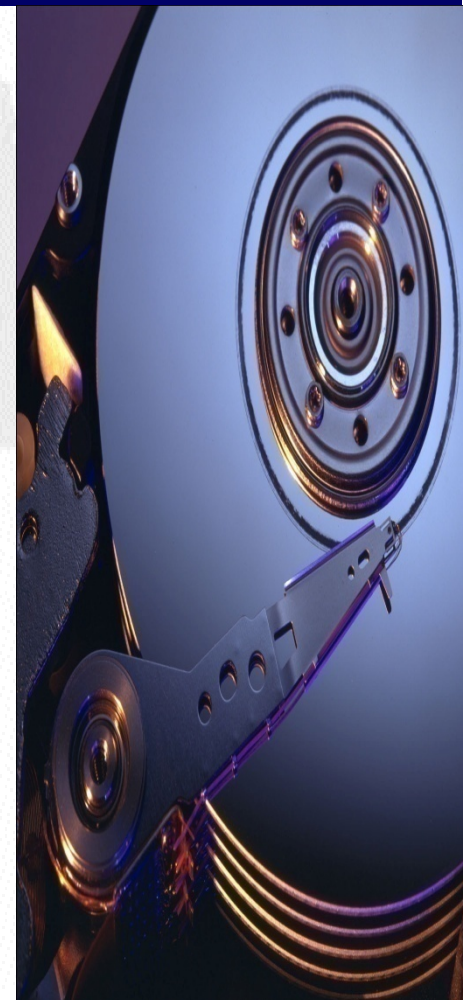



## 2.4. Damages

# Conflict situation

Does a claim for damage need direct infringement ?

## Legal basis

### Antriebsscheibenaufzug (Traction sheave elevator) (2005)

#### Decision of the Bundesgerichtshof

1. According to § 139 PatG the infringer is liable for compensation of all damages associated to the direct infringement of patentees protected rights. With respect to contributory infringement any claim for compensation requires that a case of direct infringement has taken place.

2. A potential danger that a contributory infringement may cause a damage in the future is not sufficient, since this would broaden the scope of protection of a patent in an inadmissible manner.

#### However, the decision brings up dogmatic problems according to German Patent Law:

1. Within German Patent Law there is no accessoriness between direct and indirect infringement, that means, patentees claim for compensation does not distinguish between direct and contributory infringement.

2. § 10 PatG provides an up-front protection. There is basis to distinguish between a claim for injunctive relief and a claim for damages, since § 9 PatG provides both claims equally and simultaneously to the patentee.



BGH X-ZR 247/02 (2005)

Bundesgerichtshof

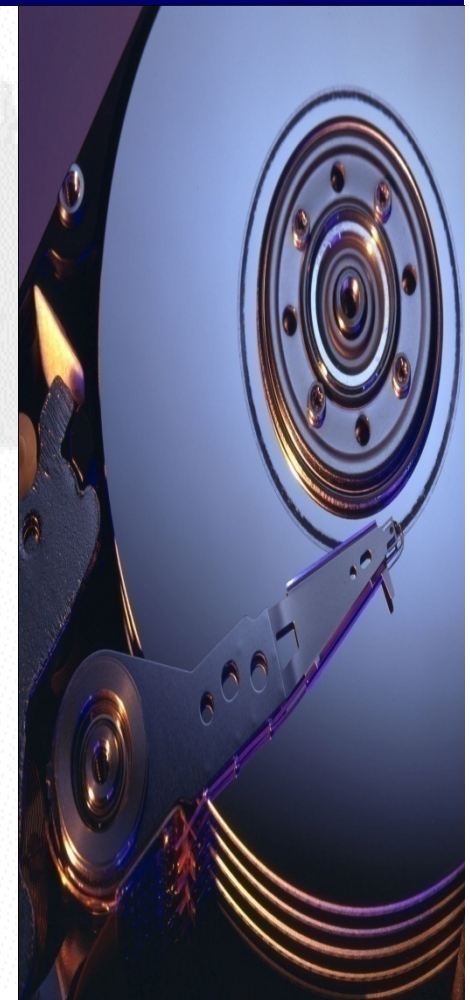





## Does German Supreme Court rule back?

Statement of Judge Meier-Beck



“

„As far it is said in the decision, any claim for compensation requires that a least one direct infringement has taken place, one should not take this too literally. With respect to the duty of compensation there is no need to deviate from earlier rulings according to which also in case of a contributory infringement the likelihood of a damage is sufficient to establish a claim.

”

Prof. Peter Meier-Beck  
BGH





## 2.4. Damages

# How to solve the problem ?

Complying with the law, but staying pragmatic

### Consequently within the law

§ 10 PatG provides patentee with an up-front right against any contributory infringer. In case of contributory infringement patentee enjoys both the right of § 9 PatG to claim for injunctive relief and compensation of damages, independent whether a direct infringement has taken place.

### Pragmatic with respect to the consequences

The claim for compensation exists for cause. For calculating its volume patentee has to provide evidences like in case of a direct infringement. In case that the contributory infringement has been stopped by injunctive relief it is very likely that the material damages are close to zero.





# Damages – revised?

Slow movement into the right direction

## Legal basis

### Haubenstretchautomat (Automatic Strech Hood) (2007)

Object of the patent has been a process for protecting goods by embedding them with a stretch foil. The characteristic feature has been the length of the transverse seam representing about 95 % of the width of the protected good. Following the instructions to use an automatic stretch hood of a supplier for foil protection equipments results in a transverse seam of 91 % of the width of the goods. Therefore, patentee sued the supplier for contributory infringement and asked the court for injunctive relief and compensation.

#### Decision of the Bundesgerichtshof

1. Due to the wording „about 95 %“ also a transverse seam of 91 % of the width of the protected good is literally encompassed by the patent claims.
2. With respect to compensation patentee is entitled to claim a compensation for the damage caused by the direct infringer and the reimbursement of any costs associated with the enforcement of its rights.
3. Patentee is free in his decision whether to sue the direct or contributory infringer; in the latter case the compensation shall be based on the profit the contributory infringer has obtained.



BGH X-ZR 137/02 (2007)

Bundesgerichtshof





## Exportation and re-importation

Realistic outlook on re-importation raises arguments for contributory infringement

### Legal basis

#### **Funkuhr II (Radio clock II) (2007)**

A supplier sold parts for radio clocks to China (unprotected area) where these components were used for the manufacture of the final products which were (re-)imported to Germany (protected area). The supplier was warned by the patentee for alleged contributory infringement and filed a negative action for declaratory judgement to a German court.

#### Decision of the Bundesgerichtshof

1. The request was dismissed.
2. A case of contributory infringement can be established even on condition that an essential element of an invention is supplied to overseas, given that said element is used for the production of goods which are protected in and assigned for importation to Germany.



**BGH X-ZR 53/04 (2007)**  
Bundesgerichtshof





## View overseas - US

Example: Eolas Technologies Inc. vs. Microsoft Corp.



“

A matter of patent infringement is also established in case a copy of a software product, that is protected by a US patent, is produced abroad using a master disk, comprising the patented software.

”





## View overseas - US

Example: NTP Inc. vs. Research in Motion, Ltd.

“

The defendant sends out e-mails using a special electronic equipment („blackberry“) from its Canadian affiliate Research-in-Motion (RIM). The Federal Circuit has come to the conclusion that it is not relevant that the host is located outside of the U.S., with respect to patent infringement it is only relevant that the customers receive and send out e-mails from the territory of the United States.

”



# Busche – Trimborn - Fabry Patent Infringement Worldwide

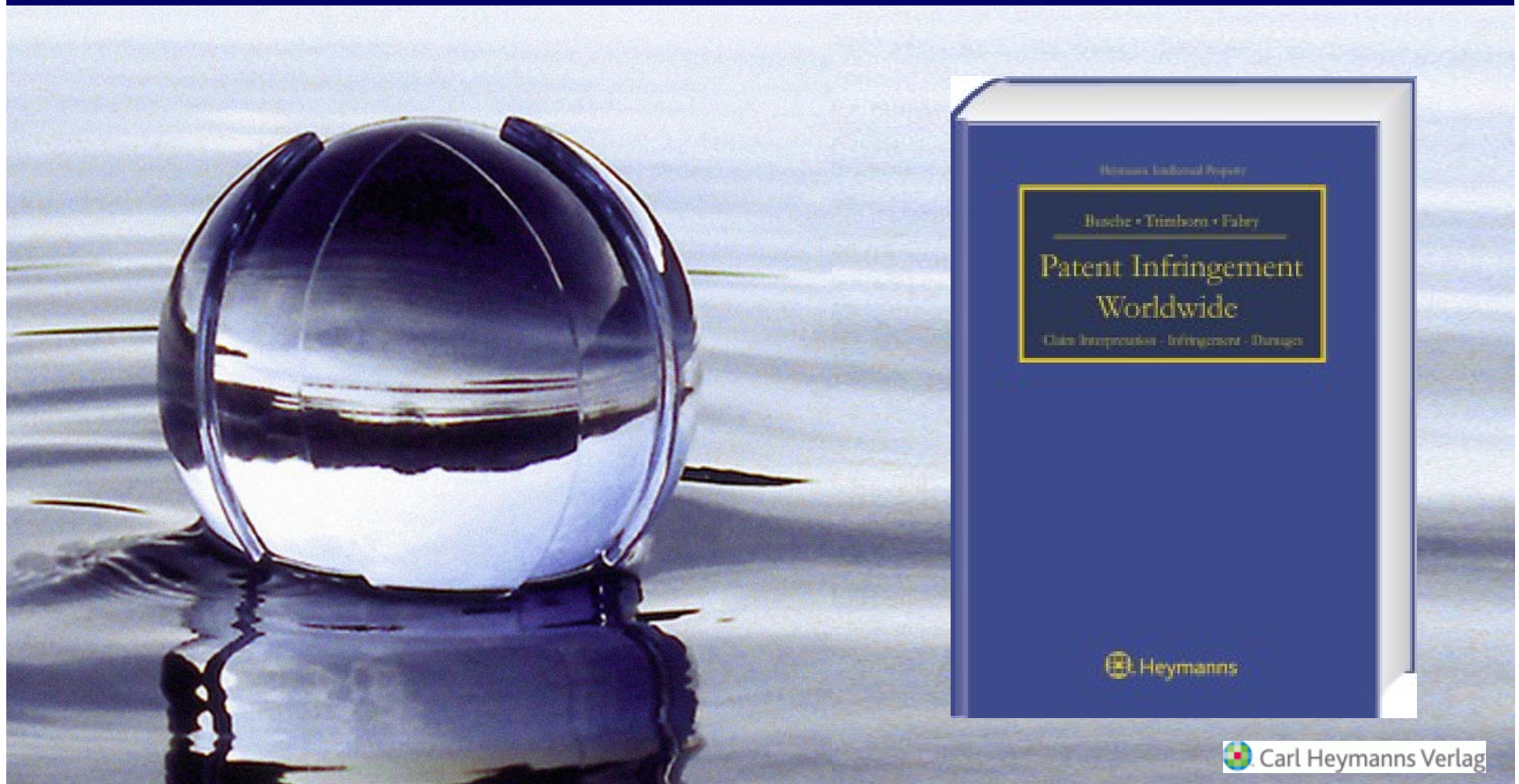

 Carl Heymanns Verlag



## Questions or need support ?

Ask your MiBs: because ...



**Dr. Bernd Fabry**

**IP<sup>2</sup> Intellectual Property**

**Tel. +49.2161.465.871**

**Fax +49.3212.465.8710**

**E-Mail: [fabry@ip-two.de](mailto:fabry@ip-two.de)**

**Homepage: [www.ip-two.de](http://www.ip-two.de)**

# IP<sup>2</sup> cares 4 U